

# 5560-G Assembly Instructions

1) **Foot & Leg Assembly (Figure one):** Align the holes on the Top Foot with the holes in the Bottom Foot and press the feet together. Position the Front Leg above the Top Foot so that the hole in the end of the Front Leg is aligned with one of the holes in the Top Foot. (The Front Leg has a hole in the side and the Back Leg does not.) Insert a Wood Screw into the bottom of the assembled feet and screw into the hole in the bottom of the Front Leg. Repeat this step using the Back Leg instead of the Front Leg. Complete 4 Foot and Leg Assemblies.

Insert the Extension between the Front Leg and the Back Leg so that the slot in the Extension is lined up with the holes in the top of the Legs. Insert a 3 1/2" Carriage Bolt through the hole in the Back Leg, then the slot in the Extension and finally the hole in the Front Leg. Secure with a Plastic Knob. (Detail A).

2) **End Assembly (Figure 2):** Insert the bolt protruding from the end of a Crossbar through the hole in the side of a Front Leg and secure with a Cap Nut. Insert the bolt protruding from the other end of the Crossbar through the hole in the side of the Front Leg of another Foot and Leg Assembly. Secure with a Cap Nut. (Detail B)

Align the hole in the end of the Notched Rail with the hole in the top of the Extension. Insert a 2 1/2" Carriage Bolt through the Notched Rail and then the Extension. Secure with a Plastic Knob. (Detail C)











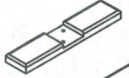





Repeat with the remaining Foot & Leg Assembly, Crossbar and Notched Rail.

3) **Q-Bar Assembly (Figure 3):** Align the holes on two Q-Bars, insert a Joint Nut into one of the holes and secure with a Joint Bolt. Repeat with the second hole in the Q-Bars.

Repeat with the remaining two Q-Bars.

4) **Frame Assembly (Figure 4):** Set the two End Assemblies approximately 5 feet apart with the Notched Rails facing inside. Line up the notches and drop the Q-Bars into Notched Rails. See reverse side for instructions on attaching your quilt.

## Part List

4	Bottom Foot	
	#60G001	
4	Top Foot	
	#60G002	
4	Front Leg	
	#60G003	
4	Back Leg	
	#60G004	
4	Extension	
	#60G005	
2	Notched Rail	
	#60G006	
2	Crossbar	
	#60G007	
4	Q-Bar	
	#60G008	
4	3 1/2" Carriage Bolt	
	#60G009	
4	2 1/2" Carriage Bolt	
	#60G010	
8	Plastic Knob	
	#60G011	
4	Cap Nut	
	#60G012	
8	Wood Screw	
	#60G013	
4	Joint Nuts	
	#60G014	
4	Connector Bolt	
	#60G015	
1	Hex Key	
	#60G016	
Phillips Hedd ScrewDriver Required for assembly		

