

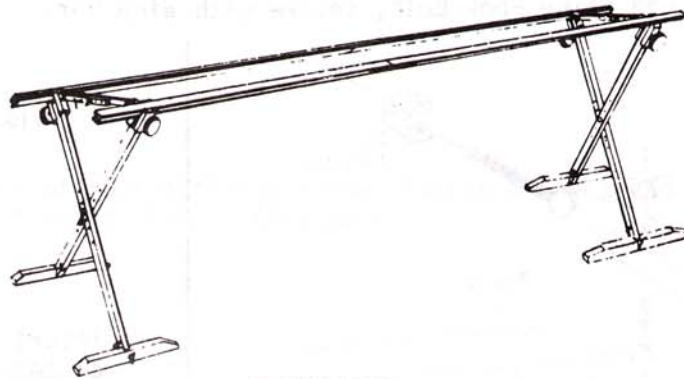

















ASSEMBLY INSTRUCTIONS for 5560-D MAPLE QUILTING FRAME



PARTS LIST

Check all parts with parts list and read instructions carefully before assembly.

| | | | |
|-------|-------|--|---|
| W-132 | 4 ea. | Foot |  |
| W-133 | 4 | Leg |  |
| W-134 | 4 | Lock Bar |  |
| W-135 | 8 | Clamp |  |
| W-136 | 4 | Quilting Bar |  |
| H-110 | 4 | Hook Bolt |  |
| H-111 | 2 | L Bar |  |
| B-114 | 12 | 1/4 - 20 Wing Nut |  |
| B-123 | 4 | 1/4 - 20 3" Carriage Bolt |  |
| B-107 | 2 | 1/4 - 20 1-1/2" Carriage Bolt |  |
| B-108 | 2 | 1/4 - 20 2" Carriage Bolt |  |
| B-106 | 4 | 1/4 - 20 1" Carriage Bolt |  |
| H-112 | 4 | U Bracket |  |
| M-105 | 4 | Knobs |  |
| H-104 | 4 | Joining Plates |  |
| B-122 | 8 | 3/16 x 7/8" Slotted Machine Screws |  |
| B-117 | 8 | 3/16" Square Nuts |  |
| B-119 | 4 | 5/8 x 17/64 x 3/64" Washers |  |

ASSEMBLY INSTRUCTIONS

STEP #1.

Attach foot to Leg using Hook Bolt, secure with Wing Nut. (Figure #1)

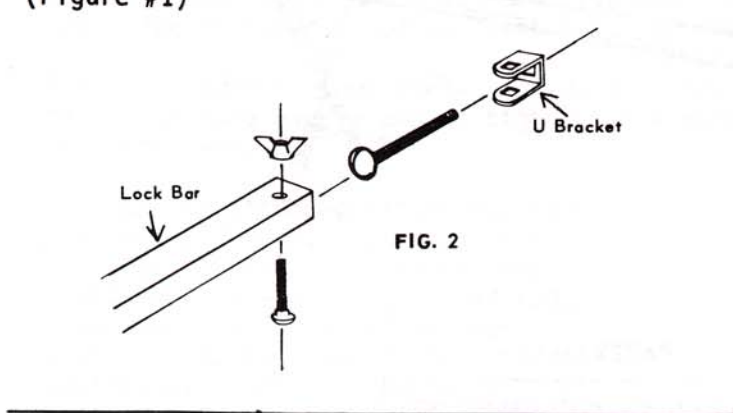
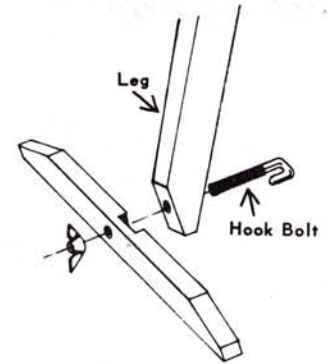
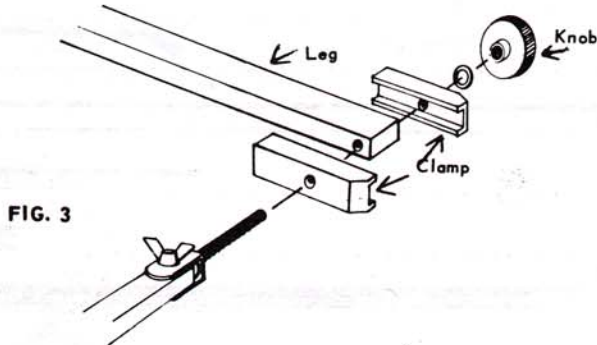

FIG.1



STEP #2.

Insert 3" Carriage Bolt through center hole in U Bracket. Attach U Bracket to end of Lock Bar using 1" Carriage Bolt. Secure with Wing Nut. (Figure #2)



STEP #3.

Insert 3" Carriage Bolt (on end of Lock Bar assembly) through first clamp, top of Leg and second Clamp, secure with Washer and Knob. (Beveled sides of Clamps are up.) (Figure #3)

STEP #4.

Assemble other 3 legs repeating steps #1, #2, and #3 for each leg.

STEP #5.

Connect 2 Leg assemblies together. Match center hole in 2 Legs, secure using 2" Carriage Bolt and Wing Nut. (Figure #4)

STEP #6.

Match 4 holes in 2 Lock Bars, insert 1-1/2" Carriage Bolt through first set, secure with Wing Nut. Slide L Bar into 4th set of holes. (Figure #4)

STEP #7.

Repeat Steps #5 and #6 using 2 remaining Leg assemblies.

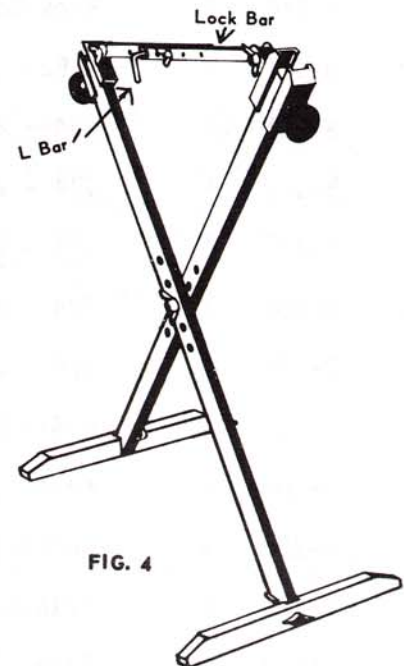

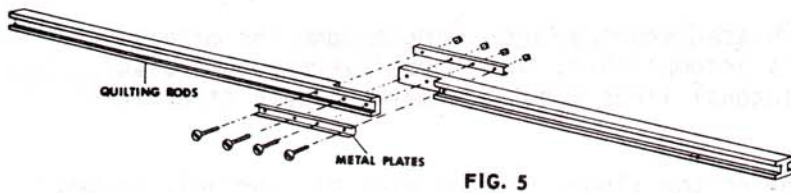

FIG. 5

STEP #8. Connect Quilting Rods using Joining Plates, 7/8" Screws and Square Nuts. (Figure #5)

STEP #9.

To complete the assembly of your quilting frame, loosen 4 Knobs and set quilting rods into position as shown. (Figure #6)

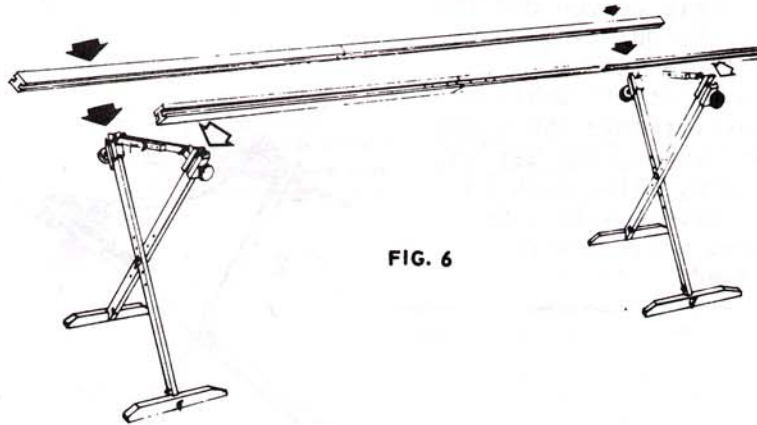

FIG. 6

SUGGESTIONS FOR THE USE OF YOUR MAPLE QUILTING FRAME

Preparing Your Quilting Rods.

After you have assembled your quilting frame, cut 4 strips of heavy cloths, (denim, duck, twill or canvas) approximately 6"x40". With carpet tacks or staple gun attach these strips to the quilting rods. These strips will be left in place even after your quilt is finished. It is best to attach 2 strips to each quilting rod so that it can later be disassembled without removing the strips. Plan to leave about 6" free at each end of the quilting rod where the rods will fit into the notches. When the rods are placed in the frame, the strips should lay toward the center of your frame. (See Figure #7).

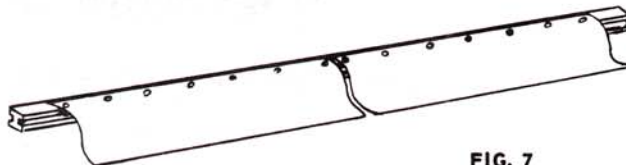

FIG. 7

Assembling Your Quilt

Place the backing on the floor and smooth it out carefully. Over this, spread the cotton batting. Now place quilt cover over batting and smooth out any wrinkles that may exist. Check to make sure that each piece of material is lined up with the others.

It is recommended that you weigh down the corners and edges with heavy objects, such as books, so that the assembly will stay together.

The three layers should now be basted together by sewing around the material, close to the edge. After this is accomplished, the three layers should also be basted together by sewing diagonal lines about 6" apart in both directions.

Attaching Quilt to Quilting Rods

Place one rod on a long table or on the floor. Pin the edge of your well basted quilt to the strips which you have fastened to the rod. The pins should go through the three thicknesses of the quilt and the strip about every 3 or 4 inches.

When this edge is completely pinned, roll the entire quilt onto this rod. This should be done evenly and as tightly as possible. Leave about 3 feet free at the other end.

Line up the second quilting rod with the one holding your quilt, and pin the edge to this strip as you did the first. Now, place the quilting rods into the notches and adjust for tautness. At this point, to achieve additional tautness, remove the L Bar from Lock Bars and swing Lock Bar up, turn quilt once more, slide Lock Bars back to position. Secure with L Bars. (Figure #8). Repeat until desired tautness is achieved.

FIG. 8

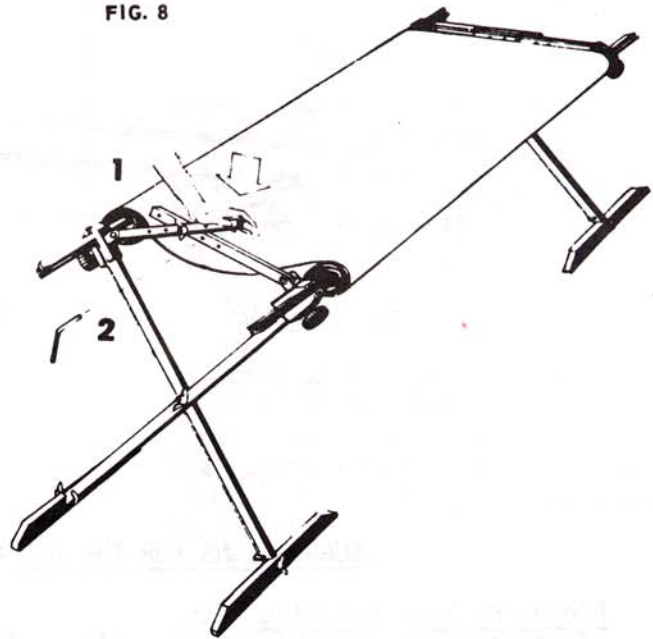
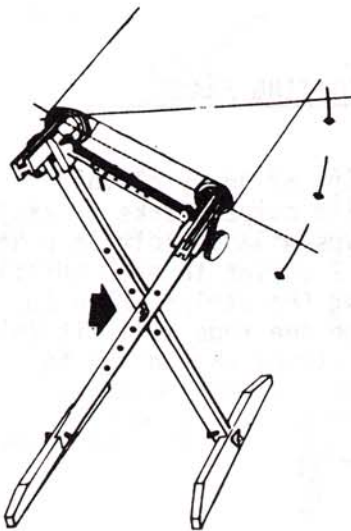

FIG. 9



Tilt Your Quilting Frame if Desired
Accomplish the desired tilt by removing Wing Nut and Carriage Bolt from center of Leg assembly and match any two holes. Re-secure, using Carriage Bolt and Wing Nut. Both Leg assemblies must be set in the same position. (Figure #9).

Easy Temporary Storage

Lift quilt and quilting rods from notches. Roll them together and tie the bundle in two or three places. (Wrapping with plastic will prevent soiling.) The Quilting Rod Support Units can easily be stored as is.